

Specification For GV Projector Mount

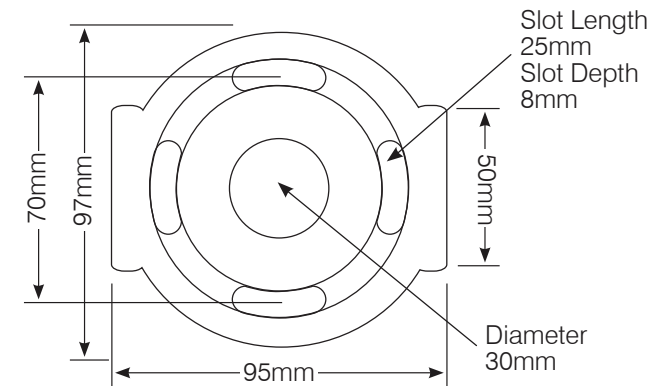
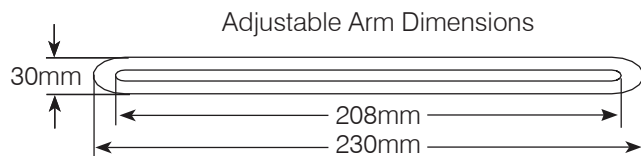
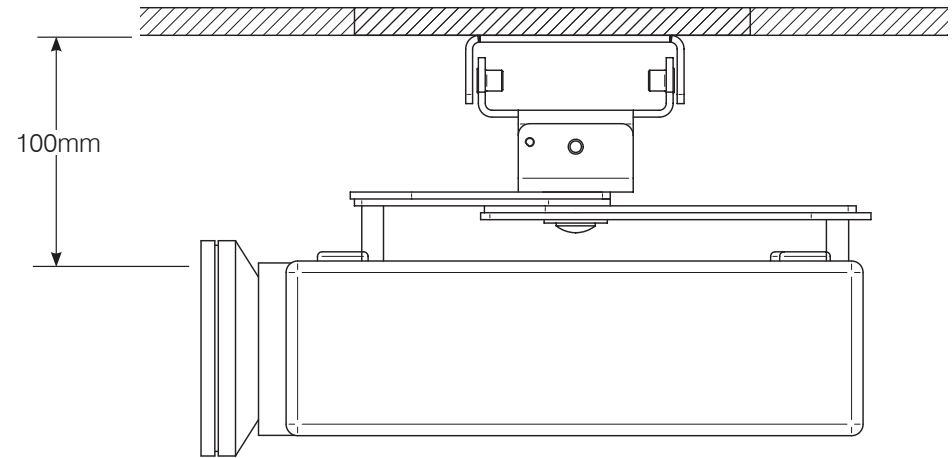
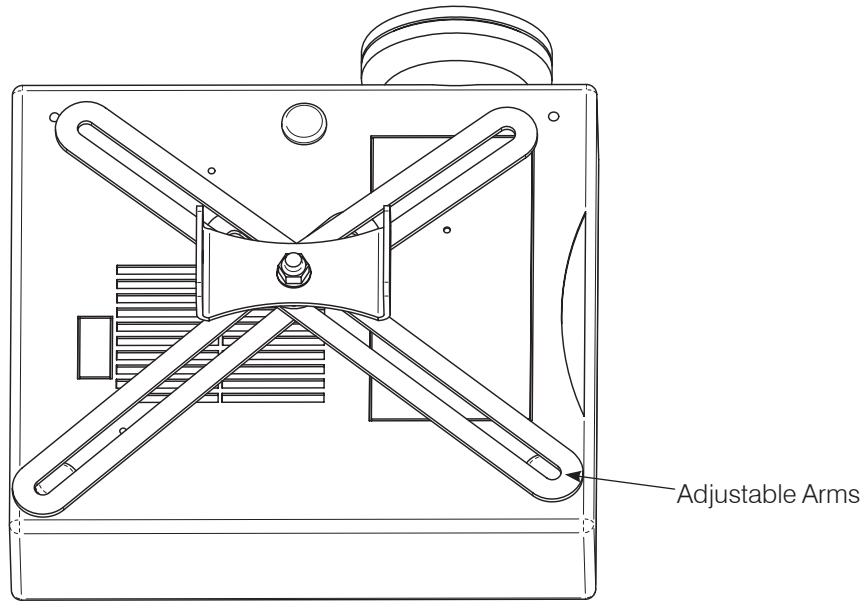

Features:

- Suits most based-mounted projectors
- M3, M4, M5 & M6 mounting bolts and springs provided
- Certified to 12kg
- Independently lockable yaw, tilt and pan adjustments
- Extension Poles available - GVMWE and GVMBE

Product Code	Colour	Maximum Projector Weight	Shipping Size (mm)
GVMBC	Black	12 kg	200 x 150 x 65
GVMWC	White	12 kg	200 x 150 x 65